

### BLOWER:

- High Efficiency Constant Airflow ECM motor engineered for continuous operation
- Dynamically balanced centrifugal blower wheel for quiet, efficient performance

### HOUSING:

- Can be mounted in any orientation to studs or joists with included brackets
- Rugged, galvanized steel construction. Overall Dimensions: 13" x 10 5/8" x 10 1/8"
- 6" round ducting, intake includes test port for airflow measurement
- Built-in motorized damper: Open when the fan runs, power close when the fan cycles/powers off
- Accepts 10 x 10 x 2 (nominal) filter up to MERV16
- 1/2" electrical connection - Hardwired by electrician



### CONTROLS:

- Accepts signal from Energy Management system
- NO/NC contact to provide signal to other eqipment

### Accessories:

- MERV-13 Air Filter MM10102-M13
- MERV-16 Air Filter MM10102-M16

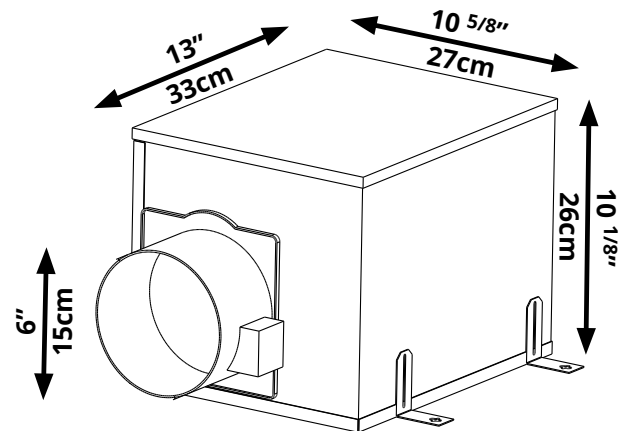

### EXPANDED PERFORMANCE

Airflow Setting	Static Pressure (Inches of w.g.)				Max Reccomended	Motor RPM	Watts	CFM / Watt**	Volts	Amps
	0.100	0.200*	0.300	0.400						
100	100	100	100	100	85	1050	12.0*	9.1	120	0.3
80	80	80	80	80	72	990	9.1	9.3		
50	50	50	50	50	42	952	6.4	8.2		

\*HVI Certified Values

\*\*As Tested

REFERENCE	QTY	REMARKS	Project
			Location
			Architect
			Engineer
			Contractor
			Submitted By
			Date